

FORD

Service Manual

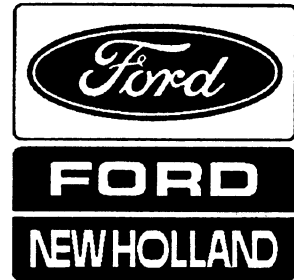

Lawn and Garden Tractors

Models 09GN2201, 09GN2202, 09GN2203, 09GN2204,
09GN2205, 09GN2206, 09GN2207, 09GN2208, 09GN2209,
09GN2210, 09GN2211, 09GN2212, 9607433, 9607434,
9607435, 9607483, 9801811

Issue 8-94

(Replaces All Previous Issues)

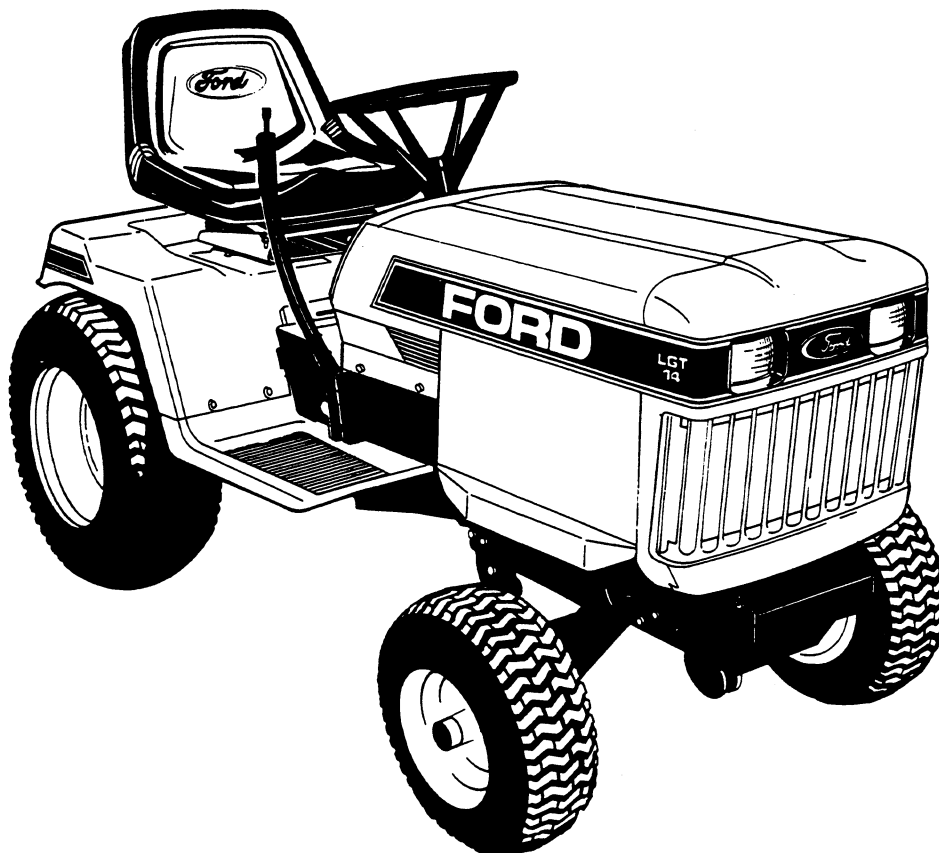

LAWN AND GARDEN TRACTOR

GENERAL INFORMATION CHART

TRACTOR	YEAR	MODEL	TRANSMISSION	ENGINE	PARTS CATALOG	FICHE
LGT12	1984-85	09GN-2201	PEERLESS 2352	KOH K301AQS	17364	226
LGT12 H	1984	09GN-2202	EATON 1100-045	KOH K301AQS	17364	226
LGT12 H	1985	09GN-2205	EATON 1100- 045	KOH K301AQS	17364	226
LGT14	1985-86	09GN-2207	PEERLESS 2352	KOH M14AQS	17364	226
LGT14	1987	09GN-2210	PEERLESS 2352	KOH M14AQS	17401	228
LGT14	1988	9607433	PEERLESS 2352	KOH M14AQS	17417	241
LGT14 H	1985-86	09GN-2208	EATON 1100- 022	KOH M14AQS	17364	226
LGT14 H	1987	09GN-2211	EATON 1100- 022	KOH M14AQS	17401	228
LGT14 H	1988	9607434	EATON 1100- 022	KOH M14AQS	17417	241
LGT17	1984	09GN-2203	PEERLESS 2352	KOH KT17QS	17364	226
LGT17 H	1984	09GN-2204	EATON 1100- 045	KOH KT17QS	17364	226
LGT17 H	1985	09GN-2206	EATON 1100- 045	KOH KT17QS	17364	226
LGT18 H	1986	09GN-2209	EATON 1100- 045	KOH M18QS	17364	226
LGT18 H	1987	09GN-2212	EATON 1100- 045	KOH M18QS	17401	228
LGT18 H	1988	9607435	EATON 1100- 045	KOH M18QS	17417	241
LGT18 H	1989	9607483	EATON 1100- 045	KOH M18QS	17463	241
LGT18 H	1990	9801811	EATON 1100- 045	KOH M18QS	17463	241
LGT18 H	1991	9801811	EATON 1100- 045	KOH M18QS	17461	243

CATALOG# FICHE#

KOHLER	4048	222
	17473	223

Engine Model

New Holland Publications Number

Kohler Publications Number

K301AQS	—	ENS-575
M14AQS	40547800	TP-2203-A
KT17QS	—	TP-2043-A
M18QS	40547900	TP-2204-A

WIRING DIAGRAM MODEL 09GN2201

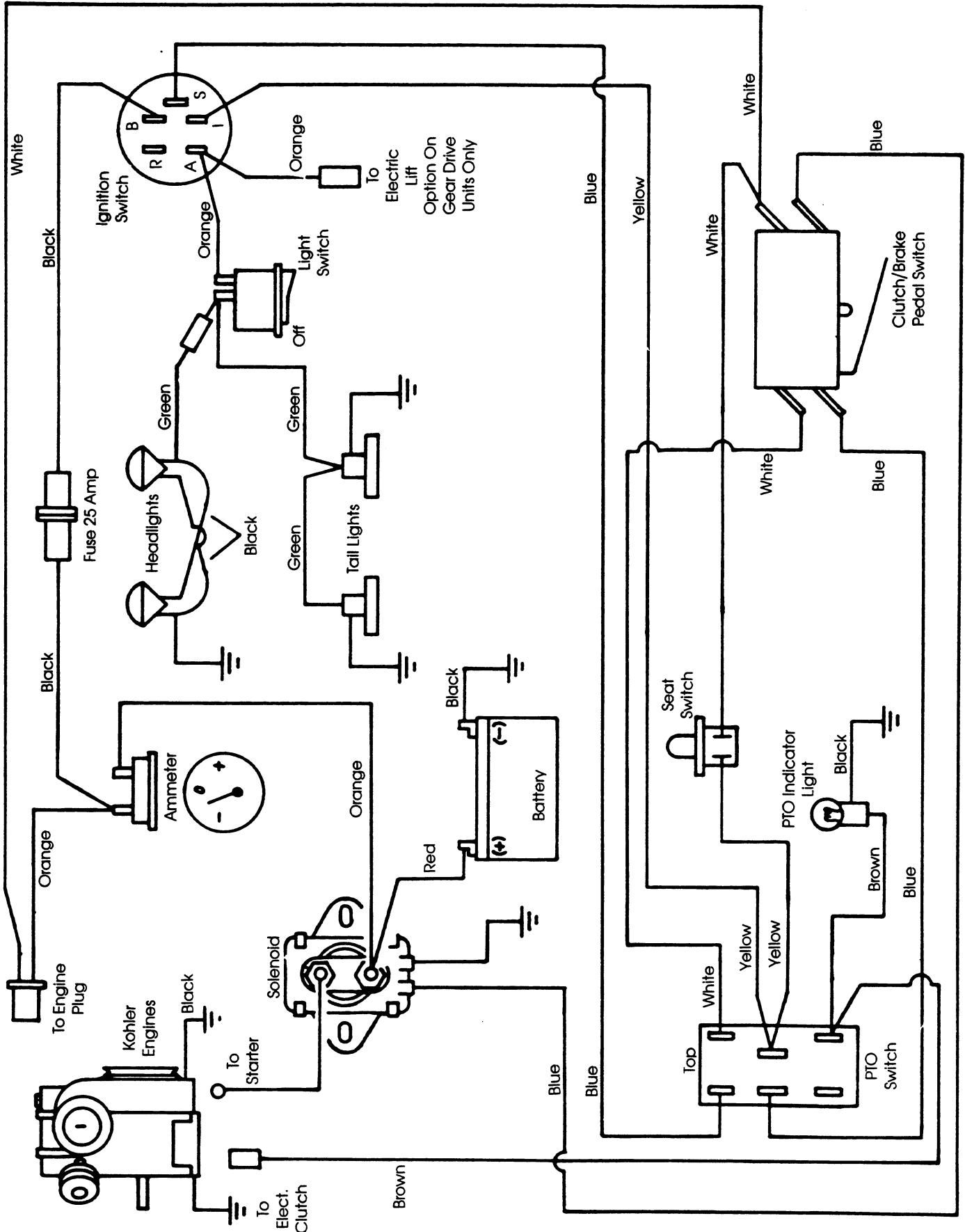

WIRING DIAGRAM MODEL 09GN2202

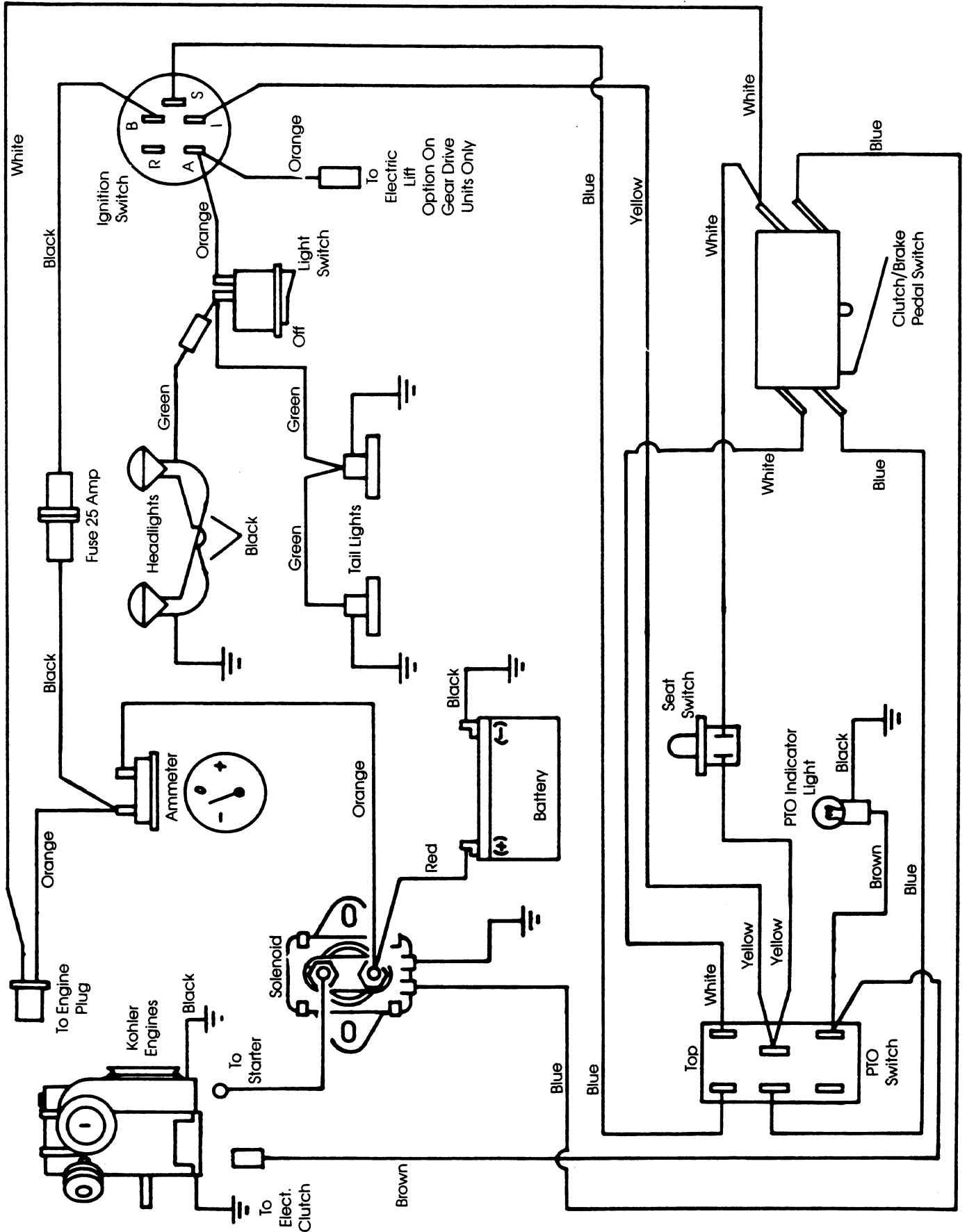

WIRING DIAGRAM MODEL 09GN2203

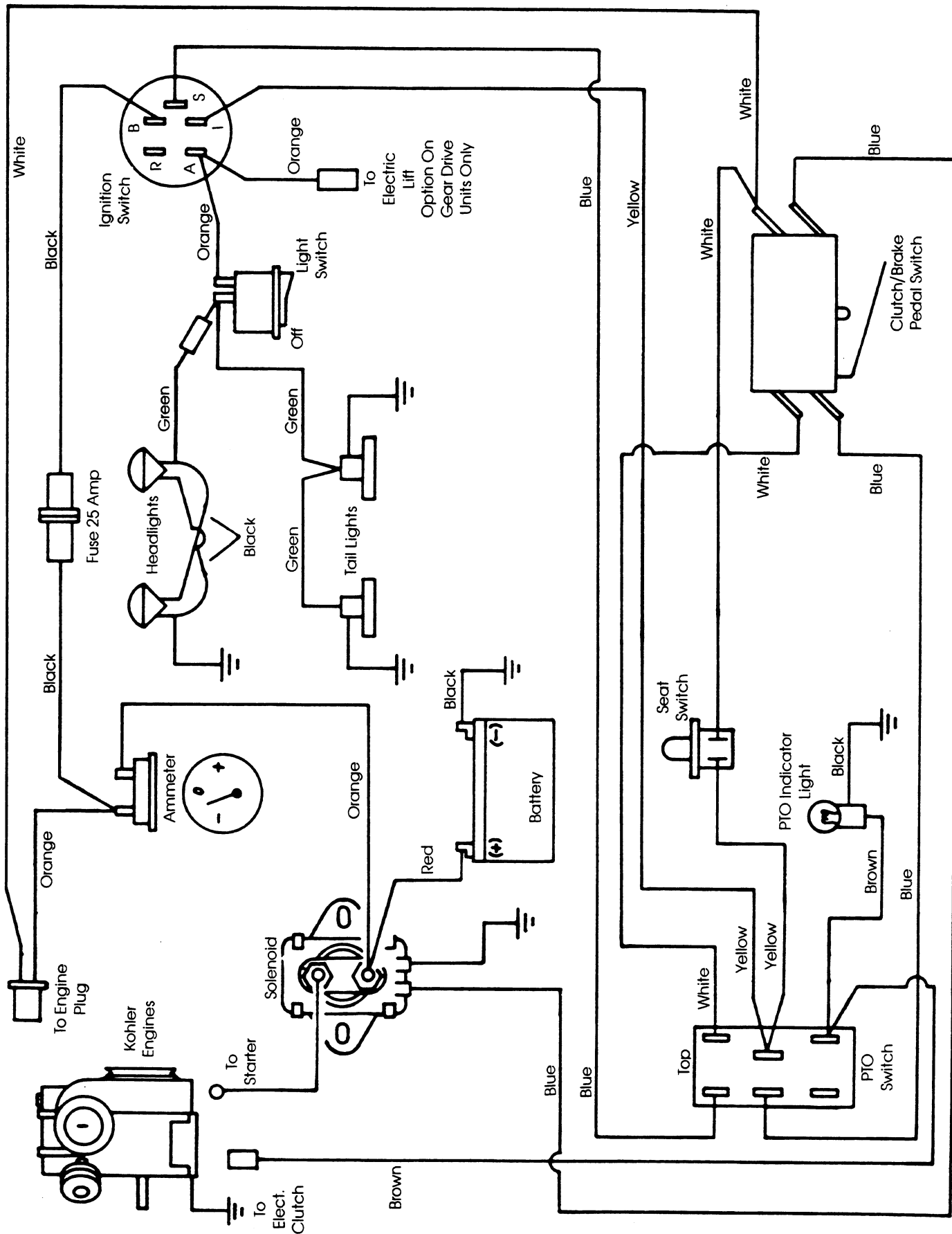

WIRING DIAGRAM MODEL 09GN2204

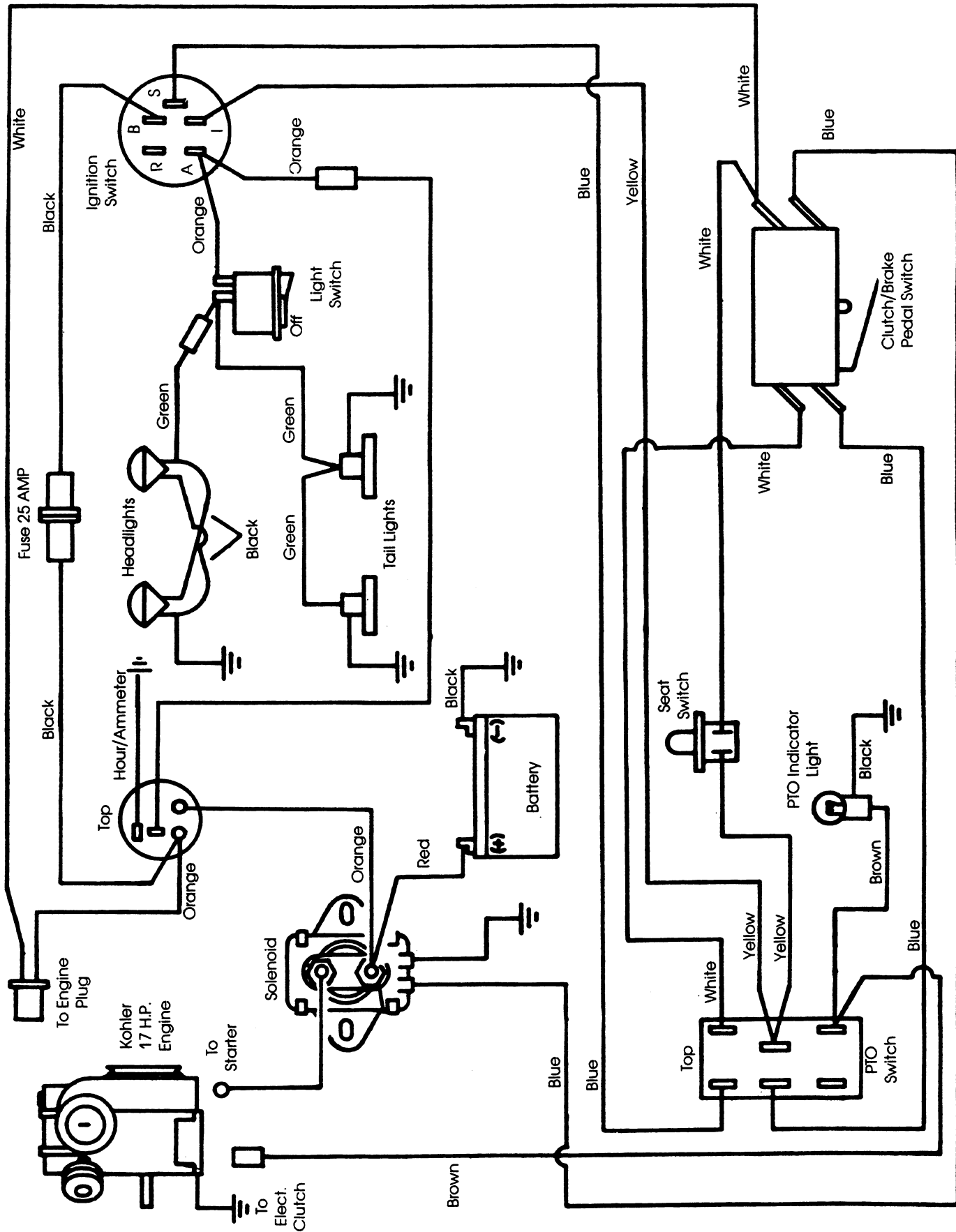

WIRING DIAGRAM MODEL 09GN2205

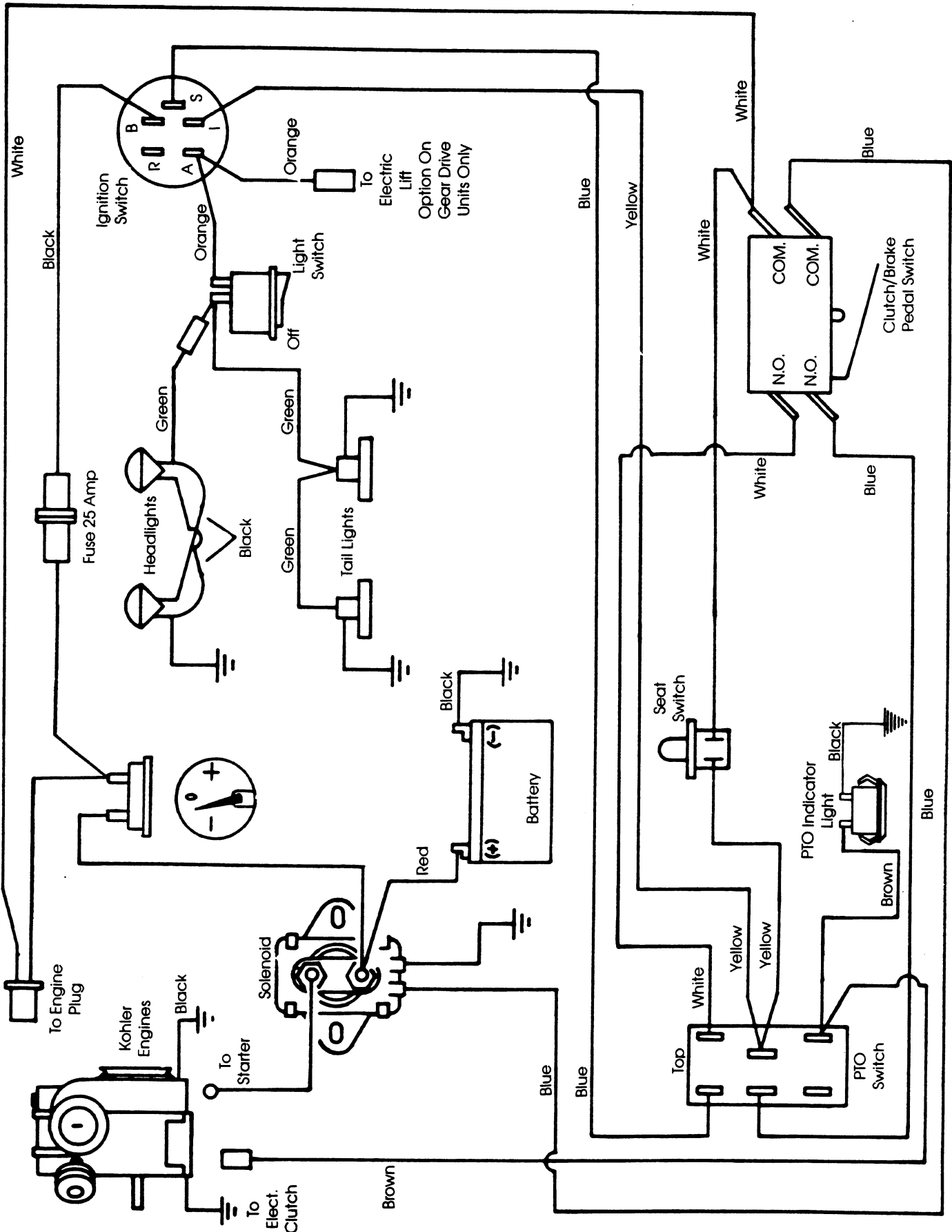

WIRING DIAGRAM MODEL 09GN2206

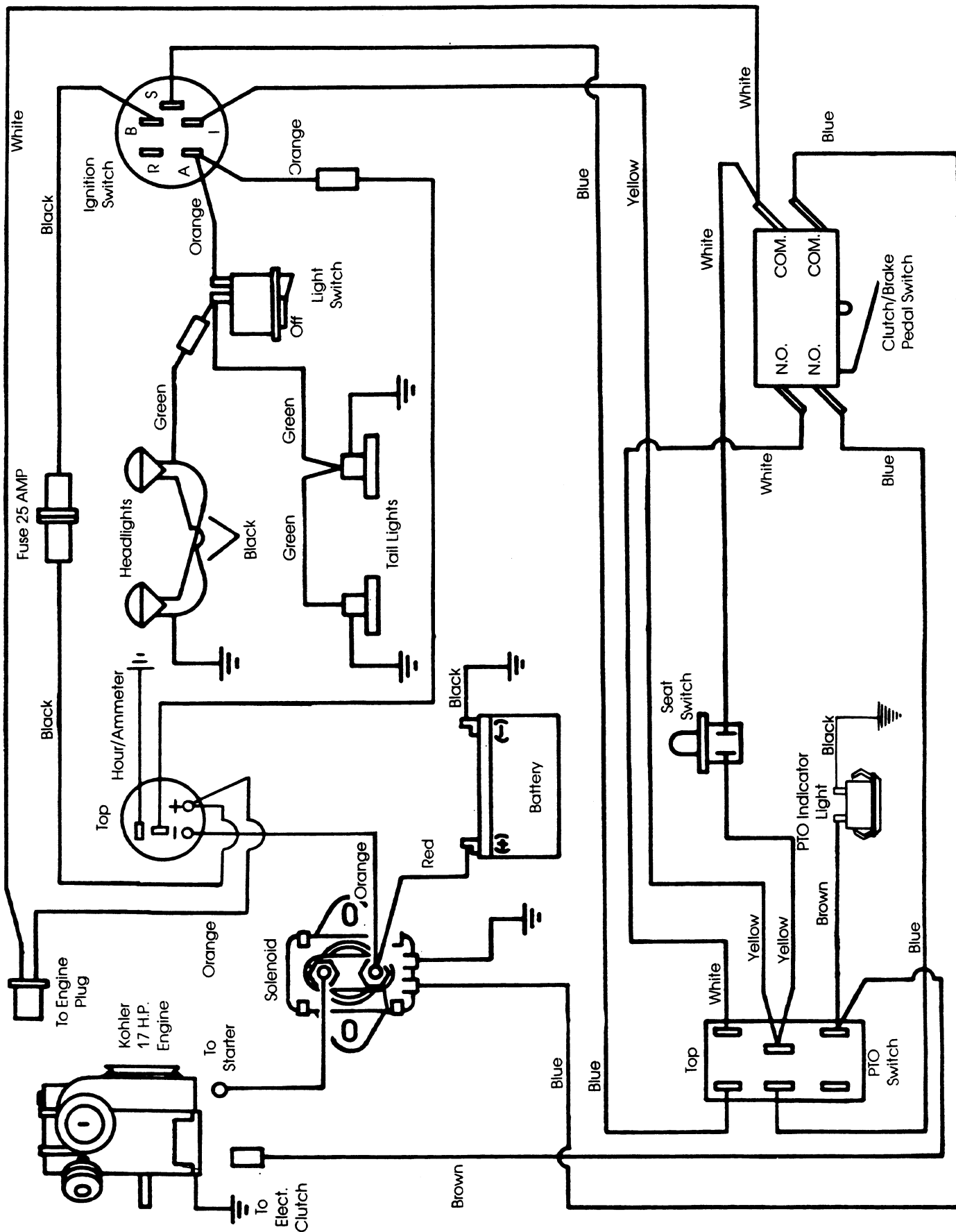

WIRING DIAGRAM MODEL 09GN2207

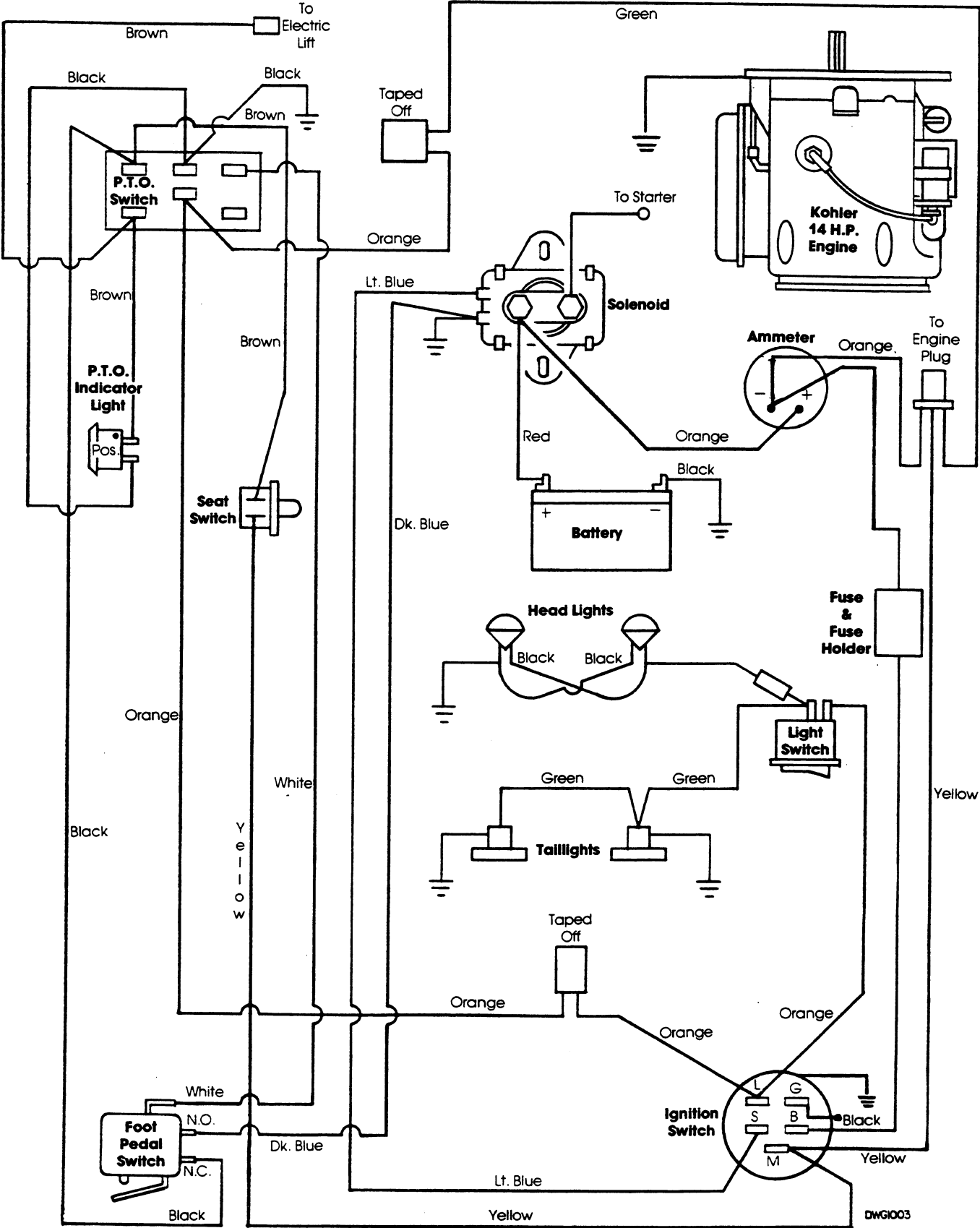

DWG1003

WIRING DIAGRAM MODEL 09GN2208

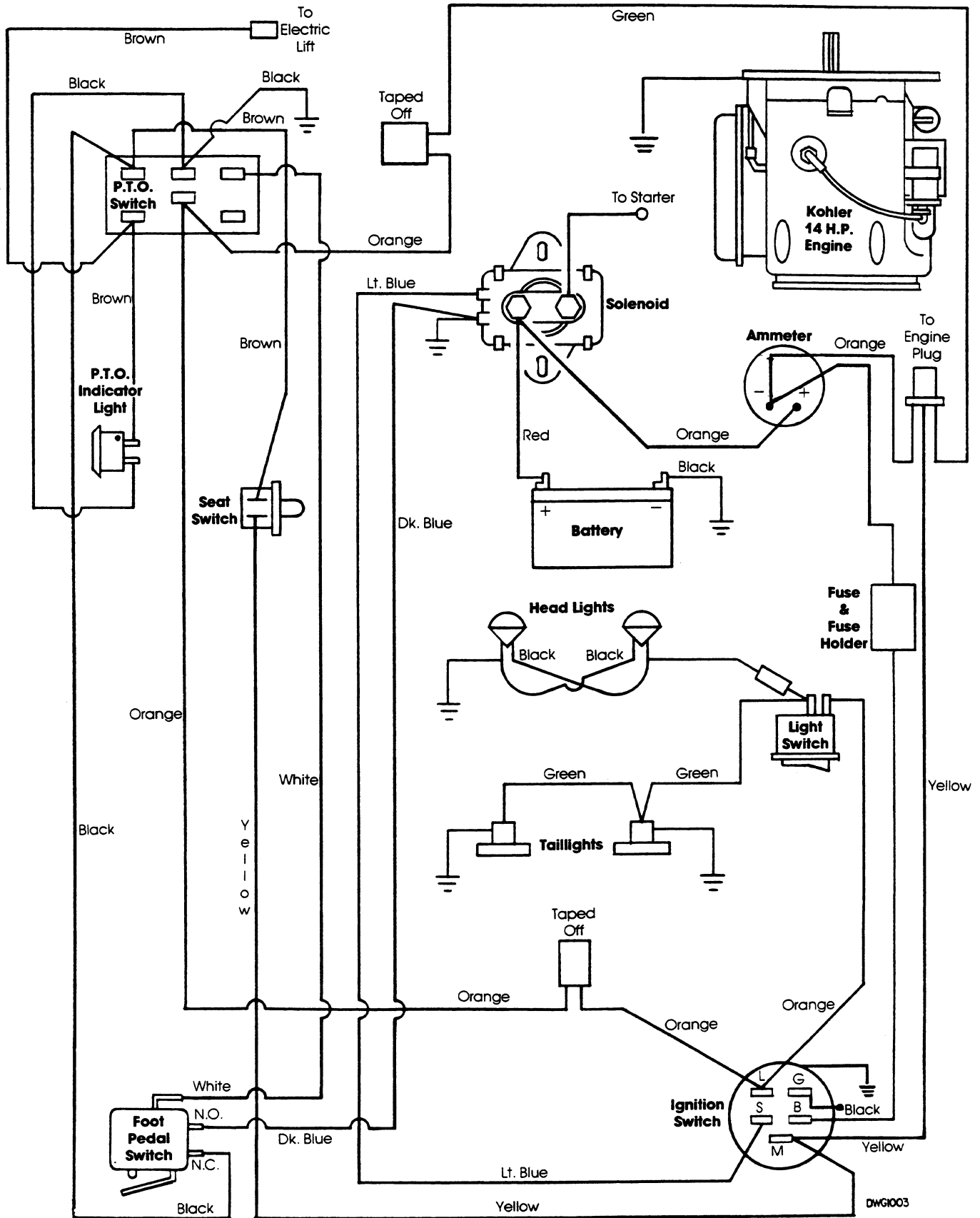

WIRING DIAGRAM MODEL 09GN2209

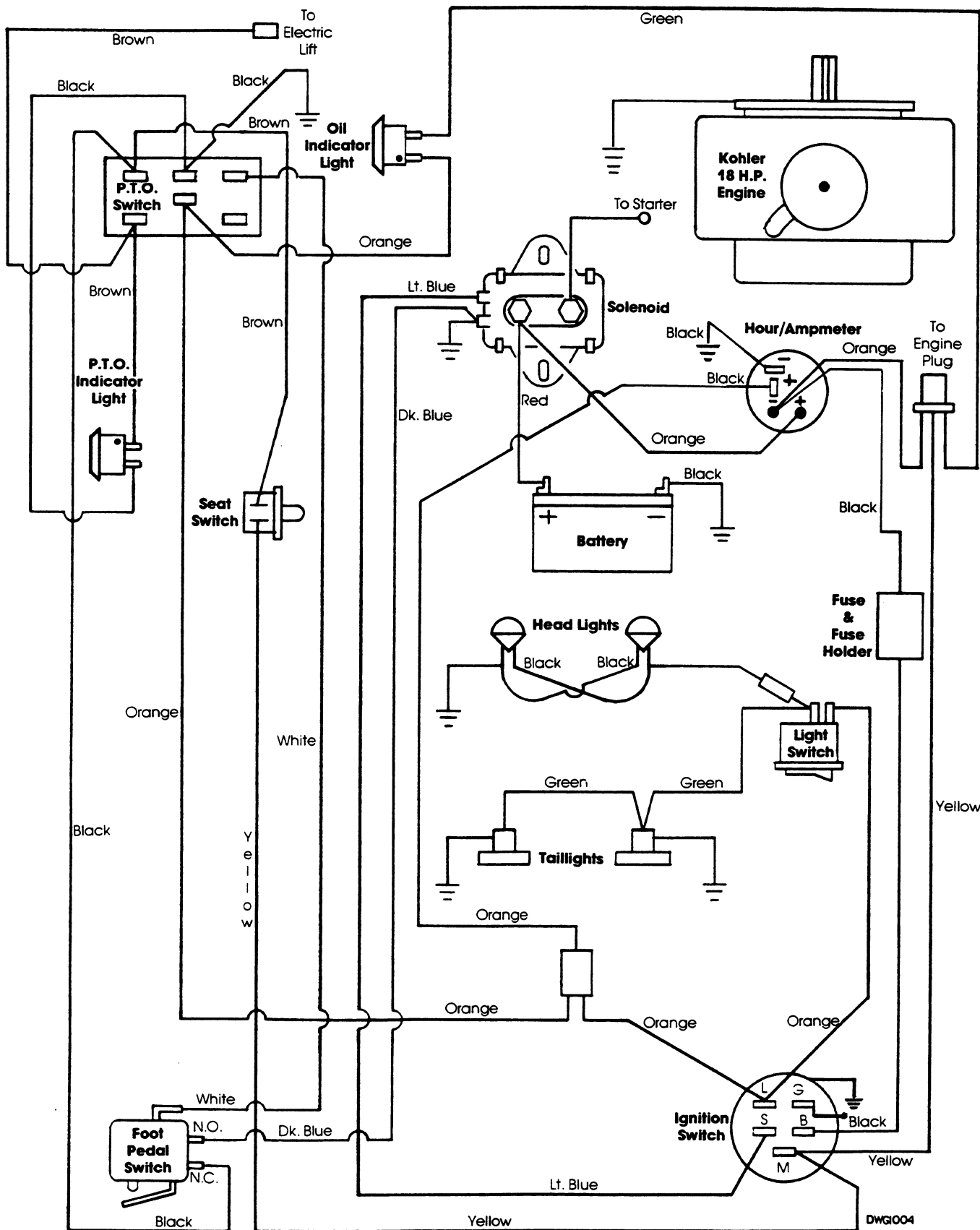

DWG1004

WIRING DIAGRAM MODEL 09GN2210

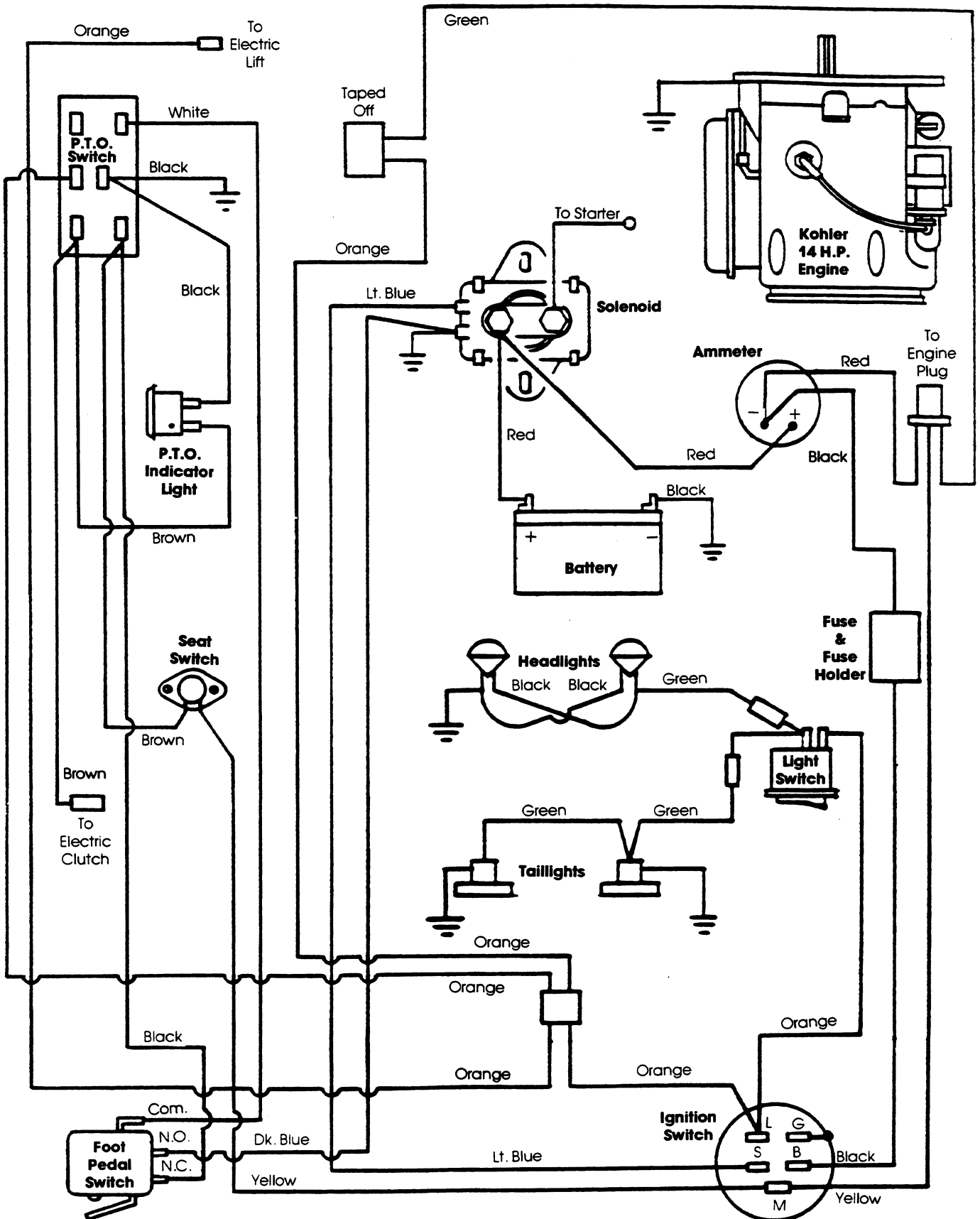

WIRING DIAGRAM MODEL 09GN2211

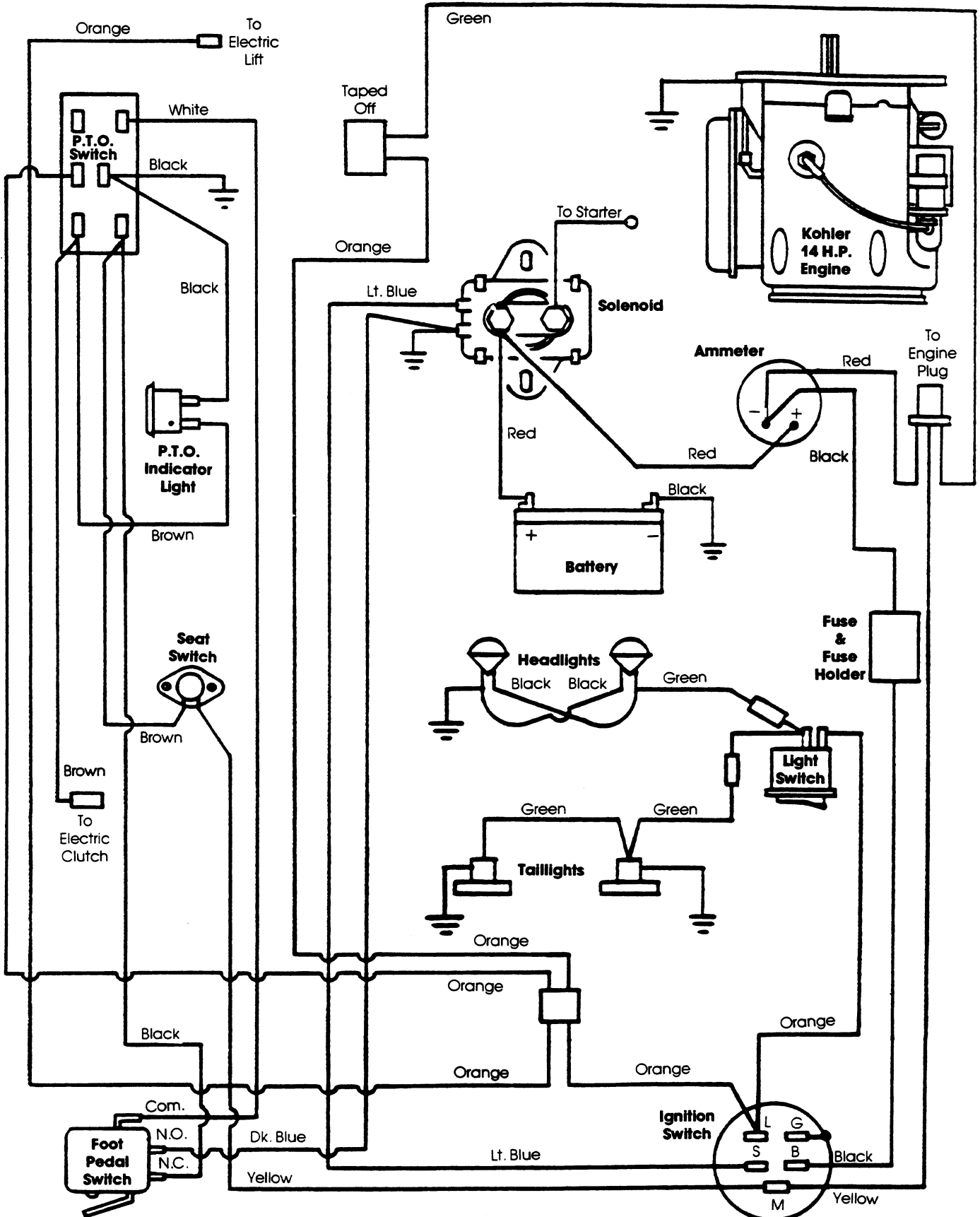

WIRING DIAGRAM MODEL 09GN2212

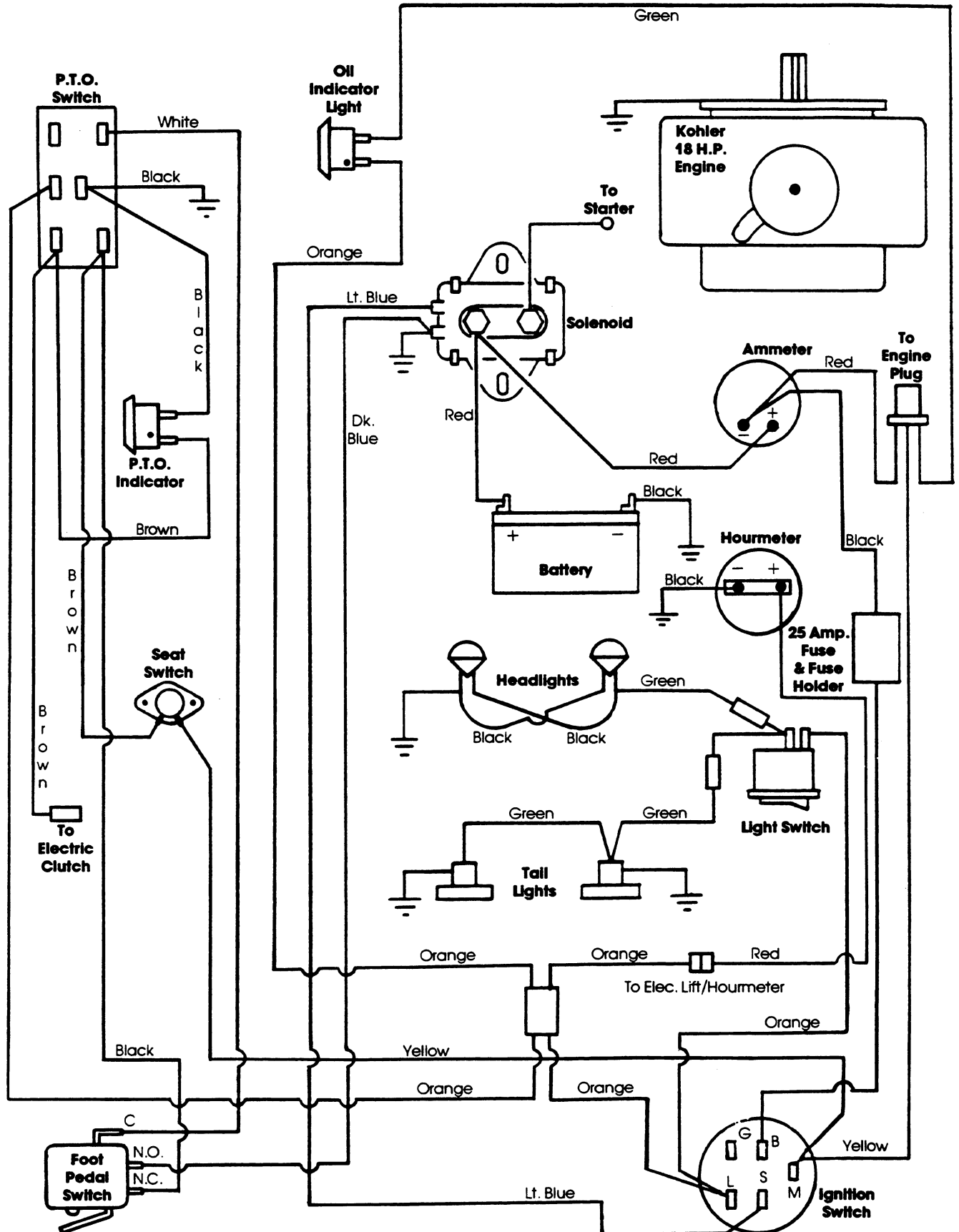

WIRING DIAGRAM MODEL 9607433

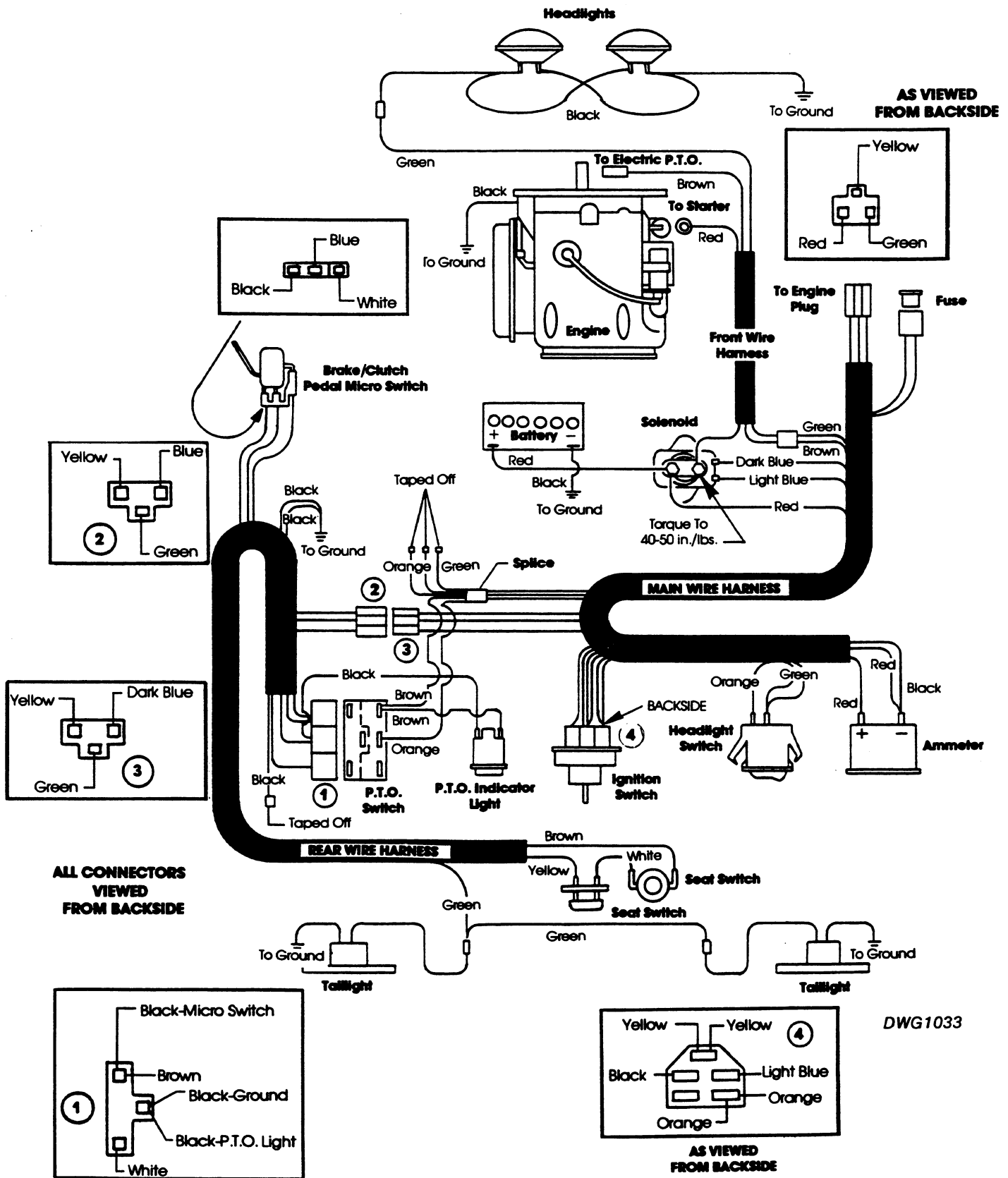

DWG1033

WIRING DIAGRAM MODEL 9607434

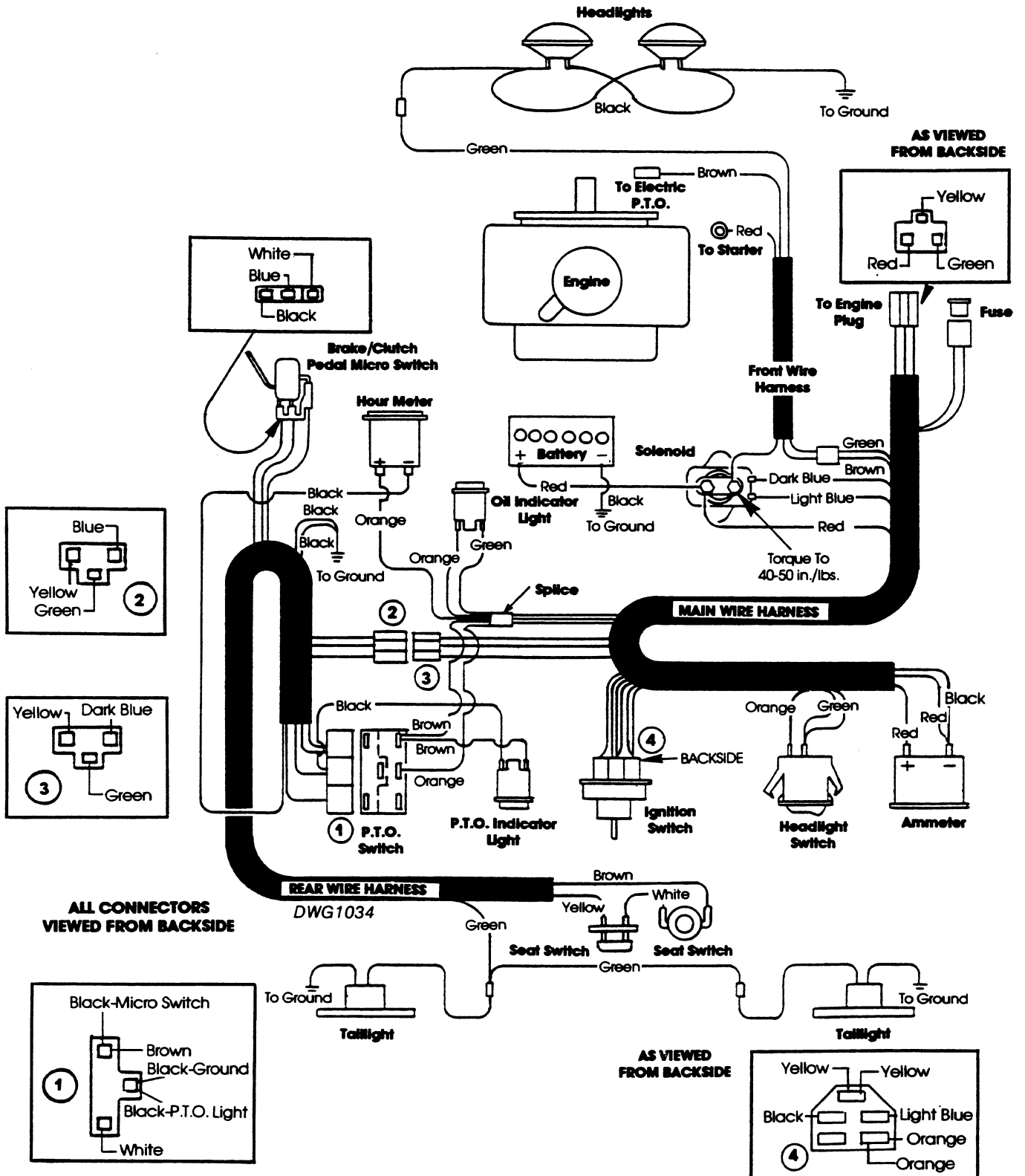

WIRING DIAGRAM MODEL 9607435

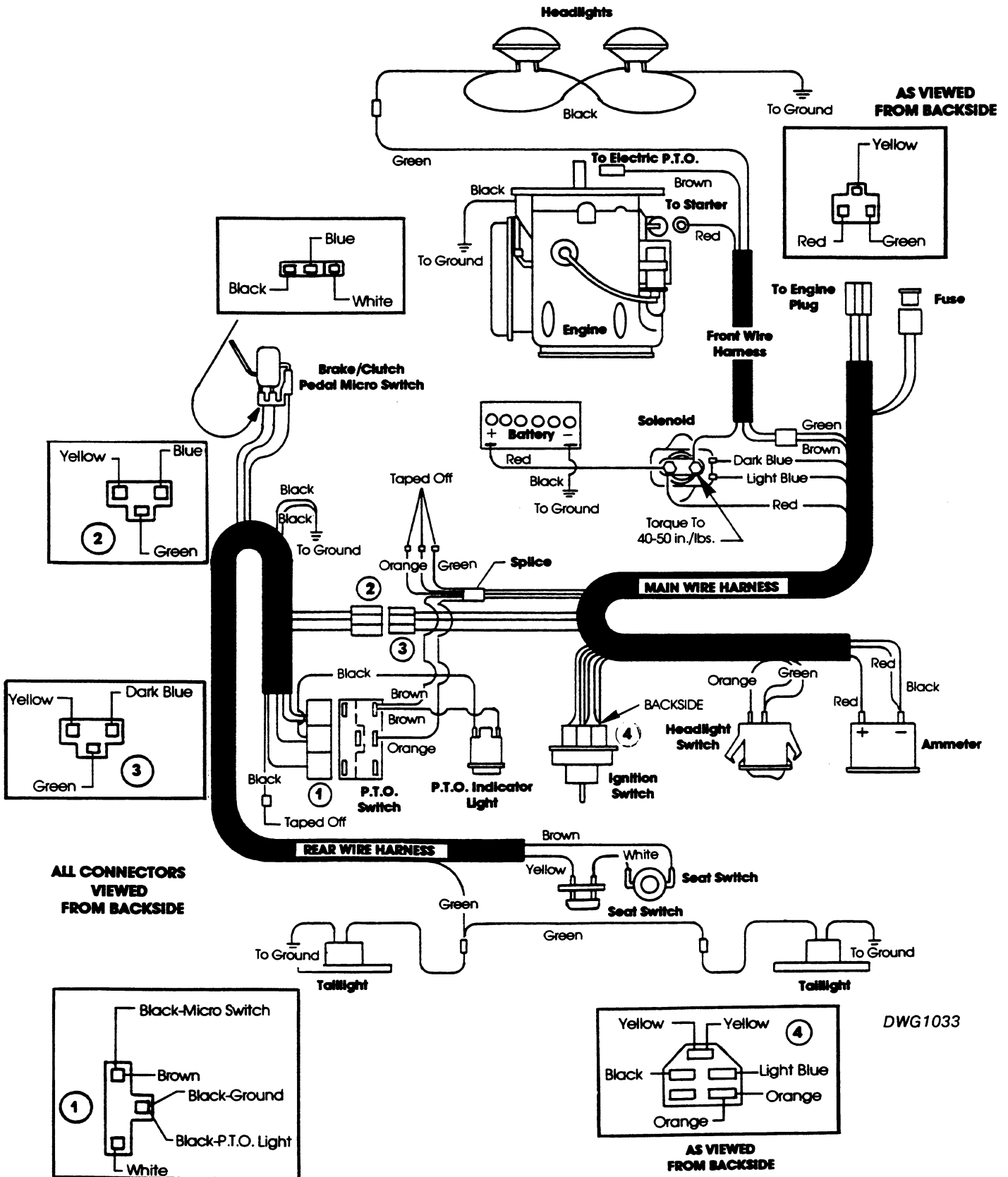

DWG1033

WIRING DIAGRAM MODEL 9607483

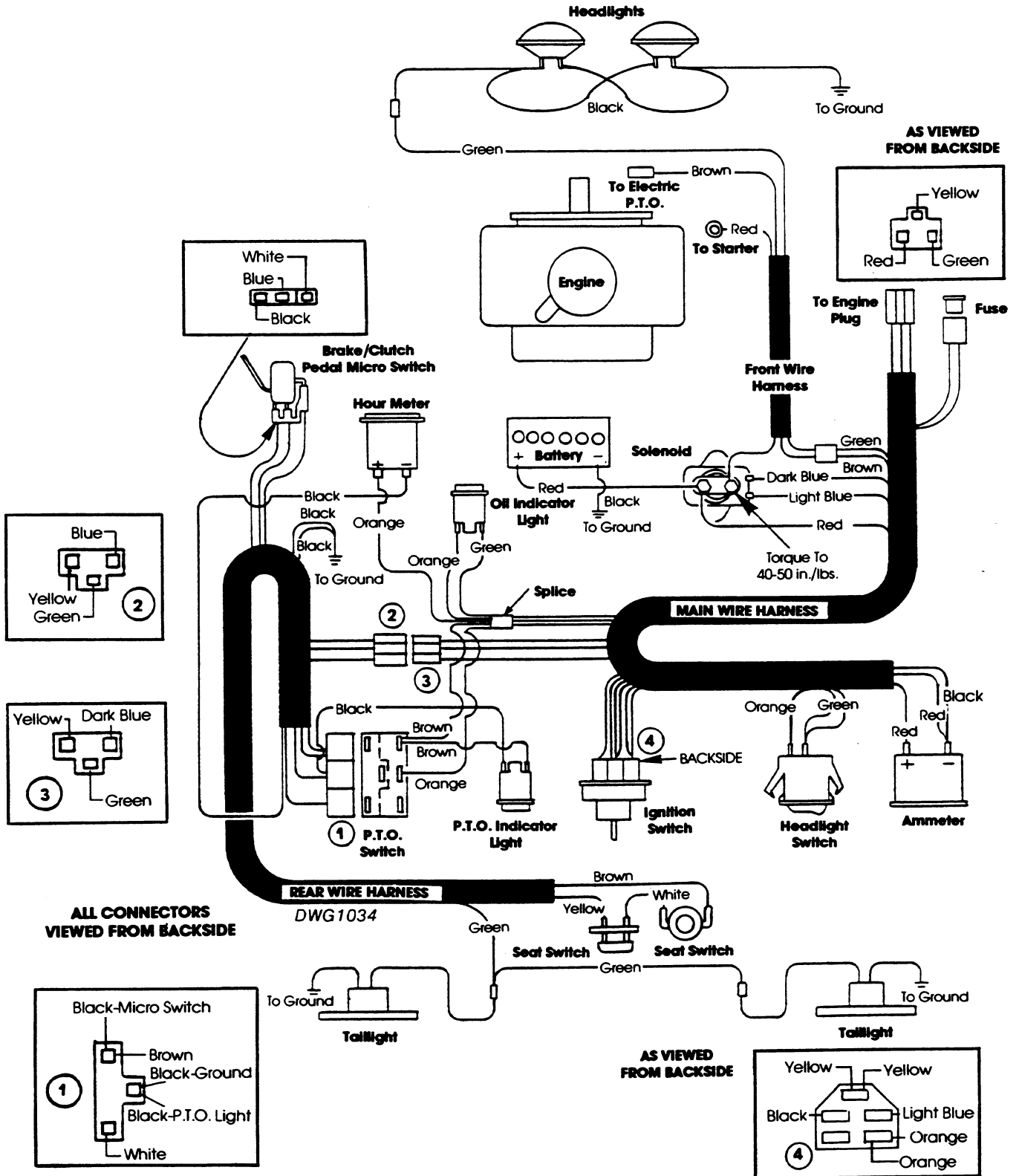

WIRING DIAGRAM MODEL 9801811

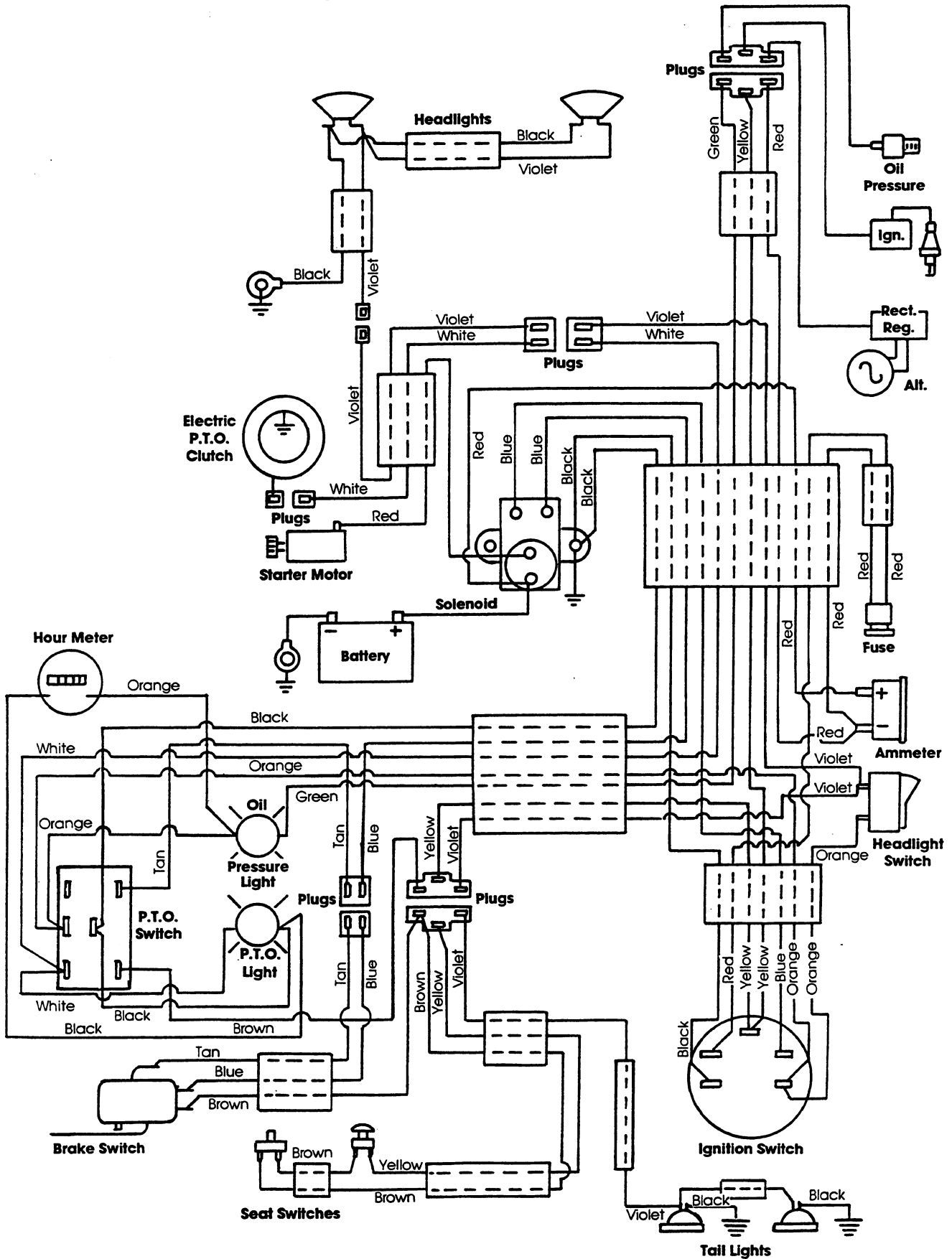

**Thanks very much for your reading,
Want to get more information,
Please click here, Then get the complete
manual**

JustClickHere 

NOTE:

**If there is no response to click on the link above,
please download the PDF document first, and then
click on it.**

**Have any questions please write to me:
admin@servicemanualperfect.com**